



REQUEST FOR QUOTATION

Date: 11 May 2023
RFQ No.: 100-23-01-160

Name of Company: _____
Address: _____
Name of Store/Shop: _____
Address: _____
TIN: _____
PhilGEPS Registration Number: _____

The City Government of Pasig, through the Bids and Awards Committee (BAC), intends to procure **Supply and Delivery of Other Supplies, Materials and Consumables - PUSO** with an Approved Budget for the Contract (ABC) of **Php 807,790.00**, in accordance with **Section 53.9** of the 2016 revised Implementing Rules and Regulations of Republic Act No. 9184. Please quote your best offer for the item in the table below.

The Project shall be awarded as One Project having several items grouped into several lots, which shall be awarded as separate contracts per lot. Quotations received exceeding each total Cost per Item and/or the total Approved Budget for the Contract shall be rejected.

Item No.	Item Description	Brand Name* <small>(PLEASE DO NOT LEAVE BLANK)</small>	QTY	UOM	Approved Budget		Price Offer	
					Unit Cost	Total Cost	Unit cost	Total Cost
LOT 1 – OTHER SUPPLIES SND MATERIALS								
1	DSLR Camera, - - MINIMUM OF TWENTY-FOUR (24) MEGA PIXEL - ATLEAST 4K AND FULL HD VIDEOS - ATLEAST DIGIC 8 PROCESSOR - WITH ATLEAST ONE (1) YEAR WARRANTY		2	pcs	47,000.00	94,000.00		
2	TB External Hard Disk, - FOUR (4) TB CAPACITY - USB POWERED OR WITH SEPARATE POWER ADAPTER - CAN BE EASILY UTILIZED FOR SAVING FILES (DRAG AND DROP) - HAS BACKUP UTILITY ORIGINALLY GIVEN BY THE MANUFACTURER - HAS LED ACTIVITY INDICATOR - FAST DATA TRANSFER THAT SUPPORTS AT LEAST USB 3.0 CONNECTIVITY		10	pcs	10,000.00	100,000.00		

	<ul style="list-style-type: none"> - SUPPORTED BY WINDOWS, MacOS or LINUX - WITH ATLEAST 1-YEAR WARRANTY 							
3	Portable Speaker w/ Amplifier, <ul style="list-style-type: none"> - SIZE 12" SPEAKER - WITH ATLEAST 1 WIRELESS MICROPHONE INCLUDED - WITH ATLEAST 500W AMPLIFIER - WITH ATLEAST 4 OHMS - WITH ATLEAST FREQUENCY RESPONSES: 50Hz-20KHz - WITH USB/BLEETOOTH/FM/LINE-IN/GUITAR INPUT/WIRED MICROPHONE INPUT - WITH ATLEAST AMPLIFIER: CLASS D DSP - WITH REMOTE CONTROL - WITH ATLEAST SIGNAL-TO-NOISE RATIO OF 71Db - WITH BUILT IN RECHARGEABLE BATTERY - WITH ATLEAST 1 YEAR WARRANTY 		7	pcs	9,000.00	63,000.00		
4	Magazine Rack, <ul style="list-style-type: none"> - 115mm X 270mm X 325mm - ANY COLOR - CARDBOARD MATERIAL - PLEASE SEE ATTACHED PICTURE 		300	pcs	200.00	60,000.00		
5	Digital Voice Recorder, <ul style="list-style-type: none"> - ATLEAST WITH 4GB INTERNAL MEMORY & MICRO SD EXPANSION - WITH AUTO VOICE RECORDING REDUCES BACKGROUND NOISE - WITH BUILT-IN, DIRECT USB CONNECTION FOR QUICK FILE TRANSFER TO PC - UP TO 55 HOURS OF BATTERY LIFE FOR EXTENDED RECORDING - WITH ATLEAST ONE (1) YEAR WARRANTY 		4	unit	7,000.00	28,000.00		
6	Executive Table, <ul style="list-style-type: none"> - WITH ATLEAST ONE (1) YEAR WARRANTY - H750mm X L1200mm X W700mm - MATERIALS: 25mm PB MELAMINE FINISH - WITH ADJUSTABLE FOOR GUIDE - WITH 3 BUILT IN SIDE DRAWERS - WITH 1 CENTER DRAWER - WITH PLASTIC GROMMET HOLE - ALL DRAWERS MUST BE WITH LOCK AND KEY - PLEASE SEE ATTACHED DESIGN FOR REFERENCE 		3	pcs	10,000.00	30,000.00		
LOT 2 – FOR PUSO OFFICE USE								
7	Coffee - 200 grams, <ul style="list-style-type: none"> - POWDERED INSTANT BLACK COFFEE - 200g SACHET - ATLEAST 1 YEAR OF EXPIRATION 		103	packs	230.00	23,690.00		
8	Fabric Conditioner, <ul style="list-style-type: none"> 		126	packs	200.00	25,200.00		

Caruncho Avenue, Brgy. San Nicolas, Pasig City, Philippines 1600





(02) 8643-1111 * (02) 8641-1111 loc 1461 *  bidsandawards@pasigcity.gov.ph *



pasigcity.gov.ph

	<ul style="list-style-type: none"> - ANTI-BACTERIAL FABRIC CONDITIONER - ASSORTED SCENT - 1 LITER PER PACK 							
9	Laundry Soap, <ul style="list-style-type: none"> - POWDERED LAUNDRY SOAP - 2 KILOS PER PACK - ASSORTED SCENTS 		54	packs	300.00	16,200.00		
10	Insect Repellant, <ul style="list-style-type: none"> - MOSQUITO AND OTHER INSECT REPELLEN - 600ML PER CAN SPRAY 		48	can	500.00	24,000.00		
11	bleaching liquid 1 liter, <ul style="list-style-type: none"> - CHLORINE BLEACH - ANY SCENTS - 1 LTR PER BOTTLE 		71	bottles	100.00	7,100.00		
12	AIR FRESHENER. <ul style="list-style-type: none"> - AIR FRESHENER SPRAY - ATLEAST 300g PER CAN - ASSORTED SCENT 		65	pcs	400.00	26,000.00		
13	Tissue Paper, <ul style="list-style-type: none"> - TISSUE PAPER ROLLS - 3 PLY 600 SHEETS 9 ROLLS PER PACK 		185	packs	200.00	37,000.00		
14	Liquid Hand Soap 500ml, <ul style="list-style-type: none"> - LIQUID HAND SOAP - ASSORTED SCENTS - 500ML WITH PUMP BOTTLE 		77	bottles	150.00	11,550.00		
15	Hand sanitizer, <ul style="list-style-type: none"> - LIQUID HAND SANITIZER - 500ML WITH PUMP BOTTLE - ASSORTED SCENTS 		70	bottles	150.00	10,500.00		
16	Dishwashing Liquid, <ul style="list-style-type: none"> - DISHWASHING LIQUID - ASSORTED SCENTS - 1 LTR PER BOTTLE 		110	bottles	200.00	22,000.00		
17	Chocolate Drink, <ul style="list-style-type: none"> - POWDERED CHOCOLATE DRINK - 120g PER PACK 		117	pack	350.00	40,950.00		
18	sugar, <ul style="list-style-type: none"> - REFINED WHITE SUGAR - GRANULATED - 1 KILO PER PACK 		500	pack	130.00	65,000.00		
19	Battery AAA - Alkaline (4pcs/pack), <ul style="list-style-type: none"> - NOMINAL VOLTAGE 1.50VOLTS - AVERAGE CAPACITY 1200mAh - DIAMETER 10.5mm - LENGTH 44.5mm 		15	pack	200.00	3,000.00		
20	Garbage bag XXL (thick), <ul style="list-style-type: none"> - 50PCS PER PACK - BLACK 		294	pack	400.00	117,600.00		
21	Battery AA - Alkaline (4pcs/pack), <ul style="list-style-type: none"> - NOMINAL VOLTAGE 1.50VOLTS - CAPACITY 2500mAh - DIAMETER 13.5-14.5mm - LENGTH 49.2-50.5mm 		15	pack	200.00	3,000.00		
Note: Other terms and conditions are stipulated in the attached Terms of Reference, if any.			Total		807,790.00			
DELIVERY TERM: Within Thirty (30) calendar days upon the receipt of Notice to Proceed.								

Caruncho Avenue, Brgy. San Nicolas, Pasig City, Philippines 1600

 (02) 8643-1111 * (02) 8641-1111 loc 1461 *  bidsandawards@pasigcity.gov.ph *

 pasigcity.gov.ph

**Indicate the BRAND NAME and its specific MODEL to be offered or attach a BROCHURE for the offered item; items such as equipment, devices, electronics, machines, drugs, medicines, medical supplies must be branded or at the very least, manufacturer shall be indicated.*

Submit this Quotation (Accomplished and duly signed by the Owner or the respective Authorized Representative indicated in the Secretary's Certificate/Special Power of Attorney) not later than the closing date specified in the Bid Notice Abstract posted in PhilGEPS website along with the following documents:

- **Mayor's/Business Permit** (or a recently expired Mayor's/Business permit together with the official receipt as proof that the prospective bidder has applied for renewal within the period prescribed by the concerned local government unit subject to submission of the Mayor's Permit before the award of contract). The nature of business as stated in the Mayor's/Business Permit should at the very least be similar or related to the project to be bid.
- **PhilGEPS Registration Number**
- **Income Tax Return** - Latest Income or Business Tax Returns filed and paid through the BIR Electronic Filing and Payment System (EFPS).
In accordance with Revenue Regulation No. 3-2005, the above-mentioned tax returns shall refer to the following:
 1. Latest Income Tax Return (ITR) - For participants already with an Annual ITR, latest ITR shall refer to the ITR for the preceding Tax Year be it on a calendar or fiscal year. For new establishments which, therefore, have no annual ITR yet, it shall refer to the most recent quarter's ITR.
 2. Latest Business Tax Return - refers to the Value Added Tax (VAT) or Percentage Tax returns covering the previous six (6) months.
- Accomplished and notarized **Omnibus Sworn Statement**
([https://www.gppb.gov.ph/assets/forms/Omnibus%20Sworn%20Statement\(Revised\).docx](https://www.gppb.gov.ph/assets/forms/Omnibus%20Sworn%20Statement(Revised).docx))
- **Proof of Authorization: Secretary's Certificate** if corporation, or **Special Power of Attorney**, if individual.

ADDITIONAL REQUIREMENTS:

For Procurement of Drugs and Medicines:

Documents from the Food and Drug Administration (FDA):

- a. Certificate of Product Registration;
- b. Certificate of Good Manufacturing Practice;
- c. License to Operate;
- d. Batch Release Certificate (*for vaccines, toxoids and immunoglobulins only*) [*to be submitted upon delivery*]; and
- e. Certificate of Analysis (*for anesthesia and antibiotics*) [*to be submitted upon delivery*].

If the Supplier is not the Manufacturer, a certification from the Manufacturer that the supplier is an authorized distributor/dealer of the products/items.

Please submit the accomplished Quotation and required documents on or before the deadline of submission at the Bids and Awards Committee (BAC) through the **Procurement Management Office (BAC Secretariat Office), 4th Floor, Pasig City Hall, San Nicolas, Pasig City.**

All documents should be submitted in a sealed brown envelope addressed to the "Bids and Awards Committee, 4th Floor, Pasig City Hall", and properly marked with the Project Title as provided herein.

The CITY GOVERNMENT OF PASIG reserves the right to reject any and all bids, declare a failure of bidding, or not award the contract at any time prior to contract award in accordance with Sections 35.6

Caruncho Avenue, Brgy. San Nicolas, Pasig City, Philippines 1600



(02) 8643-1111 * (02) 8641-1111 loc 1461 *  bidsandawards@pasigcity.gov.ph *



pasigcity.gov.ph

and 41 of the 2016 revised IRR of RA No. 9184, without thereby incurring any liability to the affected bidder or bidders.

For any clarification, you may contact us at telephone no. (02) 8641-1111 / (02) 8643-1111 loc. 1461 or email address at bidsandawards@pasigcity.gov.ph



ATTY. PONCE MIGUEL D. LOPEZ
Officer in Charge, Procurement Management Office

I hereby certify that I have read and agree to this Request for Quotation, its Terms of Reference, and Bid Bulletin/s, if any. I further certify that the products to be delivered will conform to the specifications stated in the Item Description.



Conforme:

Signature over Printed Name

Position

Duly authorized to sign quotation/offer for and on behalf of _____
(Please indicate Company Name)

Caruncho Avenue, Brgy. San Nicolas, Pasig City, Philippines 1600

 (02) 8643-1111 * (02) 8641-1111 loc 1461 *  bidsandawards@pasigcity.gov.ph *

 pasigcity.gov.ph



TERMS OF REFERENCE

Purchase Request No: 100-23-01-160

LOT 1 – Other Supplies and Materials

Item Number: 1

Digital Single-Lens Reflex (DSLR) Camera

Quantity: 2

Specifications:

- Must be from Established Brand/Branded Products
- Minimum of twenty-four (24) Mega Pixel
- At least 4k and Full HD Videos
- At least DIGIC 8 Processor
- With at least one (1) year Warranty

Item Number: 2

External Hard Disk Drive (Portable)

Quantity: 10

Specifications:

- Must be from Established Brand
- At least Four (4) Terabytes Capacity
- USB powered or with separate power adapter
- Can be easily utilized for savings files (drag and drop)
- Has backup utility originally given by the manufacturer
- Has led activity indicator
- Fast data transfer that supports at least USB 3.0 connectivity
- Supported by windows , MacOS or LINUX
- With at least one (1) year warranty

Item Number: 3

Soundsystem with Microphone

Quantity: 7

Specifications:

- With At least size 12" speaker
- With at least 500W Amplifier
- With at least 4 Ohms
- With At least Frequency Response: 50Hz-20KHz
- With USB/Bluetooth
- With at least Amplifier: Class D DSP
- With at least one (1) year warranty

Item Number: 4

Magazine Rack

Quantity: 300

Specifications:

- 115mm x 270mm x 325mm
- Any colors
- Please see attached design for reference

Item Number: 5

Digital Voice / Audio Recorder

Quantity: 4

Specifications:

- Must be from Established Brand
- At least with 4GB Internal Memory & microSD Expansion
- With Auto voice recording reduces background noise
- With Built-in, Direct USB connection for quick file transfer to PC
- Up to 55 hours of battery life for extended recording
- With at least one (1) year warranty

Item Number: 6

Executive Table

Quantity: 3

Specifications:

- With at least one (1) year warranty
- Please see attached design for reference

Item Number: 7

Office Chair

Quantity: 10

Specifications:

- High-back leatherette
- 360 swivels
- Chrome black base
- Color:Black
- With at least one (1) year warranty

LOT 2 – For PUSO Office Use

Item Number: 8

Instant Powdered Coffee

Quantity: 103 packs

Specifications:

- Branded instant black coffee
- 200g Sachet
- Must be from Established Brand
- At least 1 year of expiration

Item Number: 9

Fabric Conditioner

Quantity: 126 packs

Specifications:

- Branded Anti-bacterial fabric conditioner
- 1 liter per pack

Item Number: 10

Laundry Soap

Quantity: 54 packs

Specifications:

- Branded powdered laundry soap
- 2 Kilos per pack
- Assorted Scents

Item Number: 11

Insect Repellent

Quantity: 48

Specifications:

- Branded mosquito and other insect repellent
- At least 600ml per Tin Can spray

Item Number: 12
Bleach liquid 1 liter
Quantity: 71
Specifications:

- Branded Bleach
- 1 Liter per Bottle

Item Number: 13
Air Freshener
Quantity: 65 pcs
Specifications:

- Branded air freshner spray
- At least 300 grams per Can
- Assorted scent

Item Number: 14
Tissue Paper
Quantity: 185 packs
Specifications:

- Branded tissue paper rolls
- three (3) plies 600 sheets 9 rolls per pack

Item Number: 15
Liquid Hand Soap
Quantity: 77
Specifications:

- Branded Hand Soap
- Assorted Scents
- 500ml per bottle with pump

Item Number: 16
Hand Sanitizer
Quantity: 70
Specifications:

- Branded liquid hand sanitizer
- Assorted Scents
- 500ml per bottle with pump

Item Number: 17
Dishwashing Liquid
Quantity: 110 bottles
Specifications:

- Branded dishwashing liquid
- Assorted scents
- 1 Liter per bottle

Item Number: 18
Chocolate Drink
Quantity: 117 packs
Specifications:

- Branded powdered chocolate drink
- 1.2 grams per pack

Item Number: 19
Sugar
Quantity: 500 packs
Specifications:

- White granules
- 1 Kilo per pack

Item Number: 20

AAA Battery -Alkaline (4pcs/pack)

Quantity: 15 packs

Specifications:

- Must be Branded

Item Number: 21

Garbage bags XXL (thick)

Quantity: 294 packs

Specifications:

- 50 pcs per pack
- Black

Item Number: 22

AA Battery-Alkaline (4pcs/pack)

Quantity: 15 packs

Specifications:

- Must be Branded

Prepared and Submitted by:

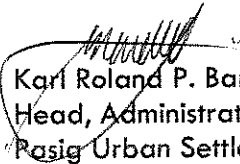

Karl Roland P. Barracas
Head, Administrative and Research Division
Pasig Urban Settlements Office

Noted By:



Ricardo B. Reyes
Officer In Charge
Pasig Urban Settlements Office

ITEM # 4
MAGAZINE RACK

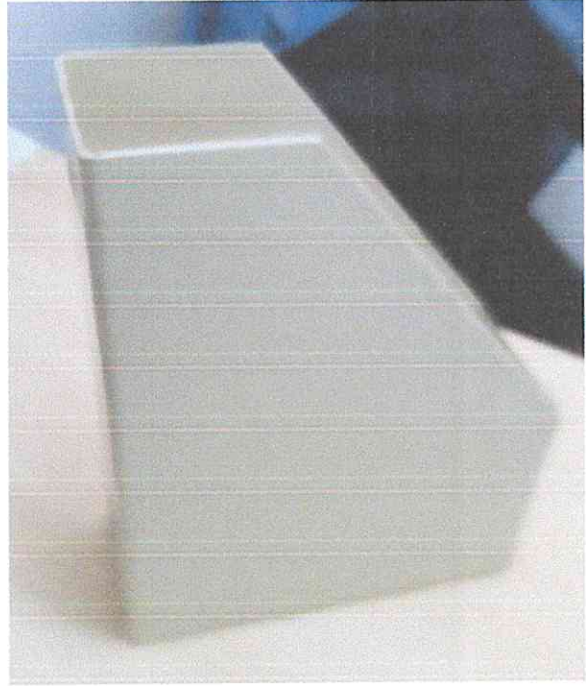

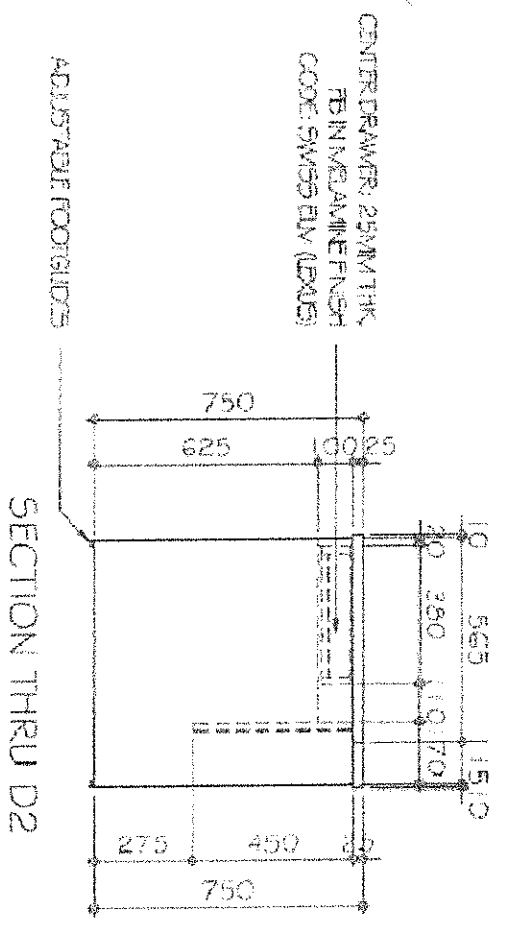
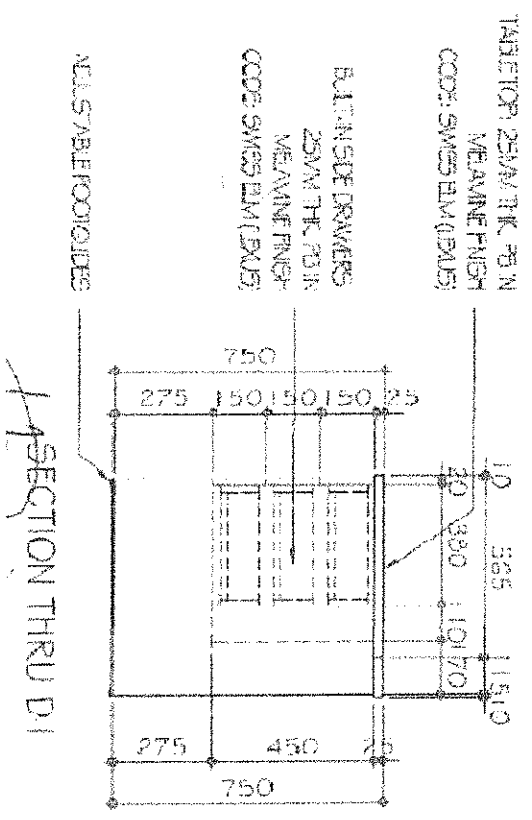
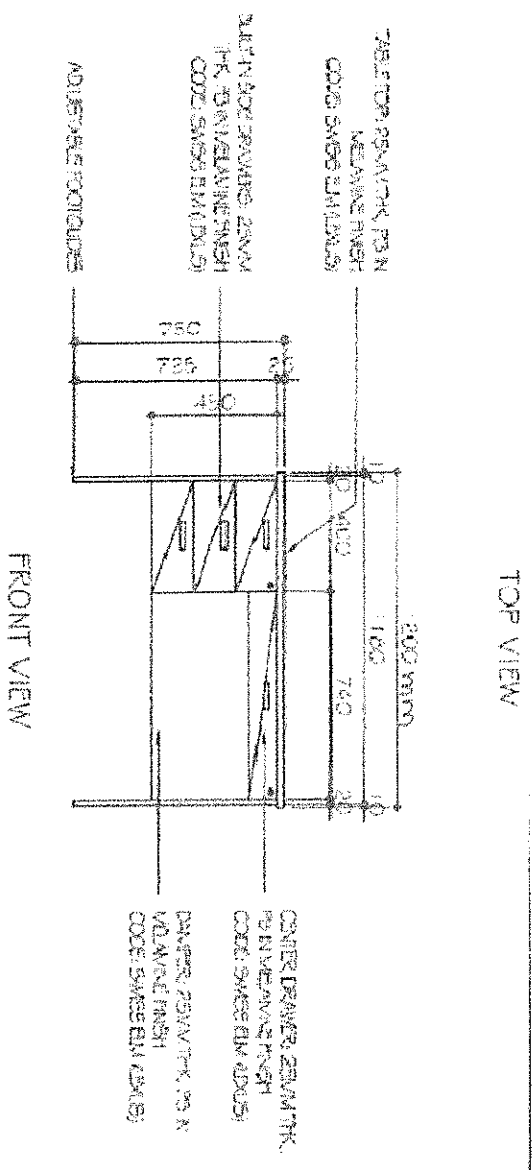
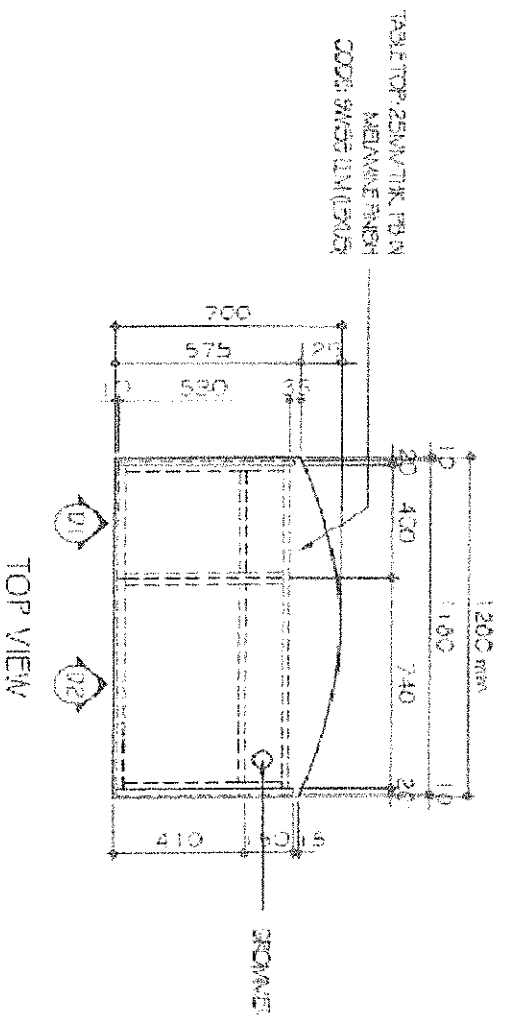

EXECUTIVE TABLE

ITEM # 6